

12π Basshorn Subwoofer Usage Notes

Please read this document carefully

- Frequency Response is 30Hz to 200Hz +/-3dB. However, the recommended range is 30Hz to 100Hz. A 30Hz high-pass filter is recommended, 24dB/octave for best power handling. This will ensure the drivers aren't subjected to signals that would cause over-excursion. High power levels of signal content below 30Hz will cause over excursion, which will result in damage to the loudspeaker.
- There are two drivers, each connected to a pair of terminals on the Speakon™ connectors. The left driver is connected to 1[+] and 1[-], and the right driver is connected to 2[+] and 2[-]. If using a single amplifier, connect 1[+] and 2[+] together externally, in the cable. Also connect 1[-] and 2[-] together. Failure to do so will result in reduced output and damage to the loudspeaker.
- Two Speakon™ connectors per cabinet are provided. Each is wired in parallel, so loudspeakers can be daisy-chained together.
- Maximum RMS voltage is 60VRMS, which corresponds to 1600 watts RMS. When choosing an amplifier, it is best to choose one capable of at least 60VRMS at 4Ω. An amplifier rated for 2000 watts at 4Ω per cabinet is a good choice. Alternatively, a pair of 1000 watt amps, each driving one side can be used.
- When connecting two separate amps to power each driver individually, be sure proper polarity is used so that the drivers are operated in phase. Failure to do so will result in reduced output and damage to the loudspeaker.
- The internal path length of the horn is 9.3 feet. The speed of sound is 1129 feet per second, so sound takes 8.3mS to reach the mouth. If a delay processor is available, it may be desirable to delay the main speakers by this amount, to compensate for path length delay in the horn sub. Another method is to position the main speakers 9.3 feet behind the subs. Consider the distances between each loudspeaker and the audience when calculating sound path lengths.
- A single 12π basshorn produces 105dB with 1 watt input, measured 1 meter (3.3 feet) from the mouth. At 10 meters (33 feet), 100 watts will produce 105dB. Maximum output of one cabinet is 137dB at one meter, which is 117dB at ten meters.
- When cabinets are grouped together, there is a 6dB gain for each doubling of cabinets. A pair of cabinets produces 6dB more output than a single, four cabinets produces 6dB more, eight cabinets produces 6dB more, and so on.
- The drivers employ a patent pending cooling system which conducts motor heat out to the aluminum side panels. These serve as heat sinks which dissipate heat into the surrounding air. Not much airflow is required for them to work because surface area is large. However, you naturally do not want direct sunlight to heat the panels, which would greatly reduce their effectiveness. If the speakers are used in direct sunlight, it is advisable to shade the side panels. One way to do this is with a snap-on denim flap shade. Contact π Speakers for details.

External Panels

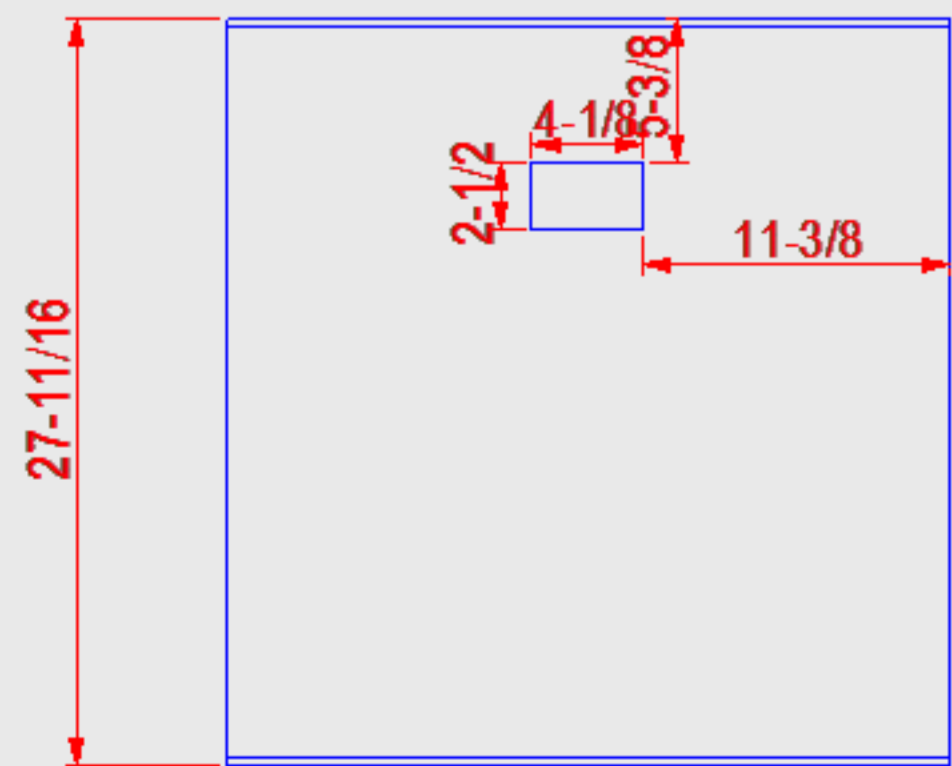
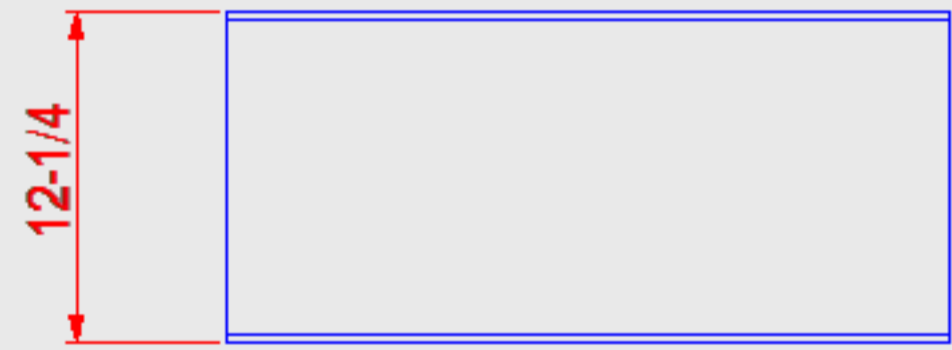
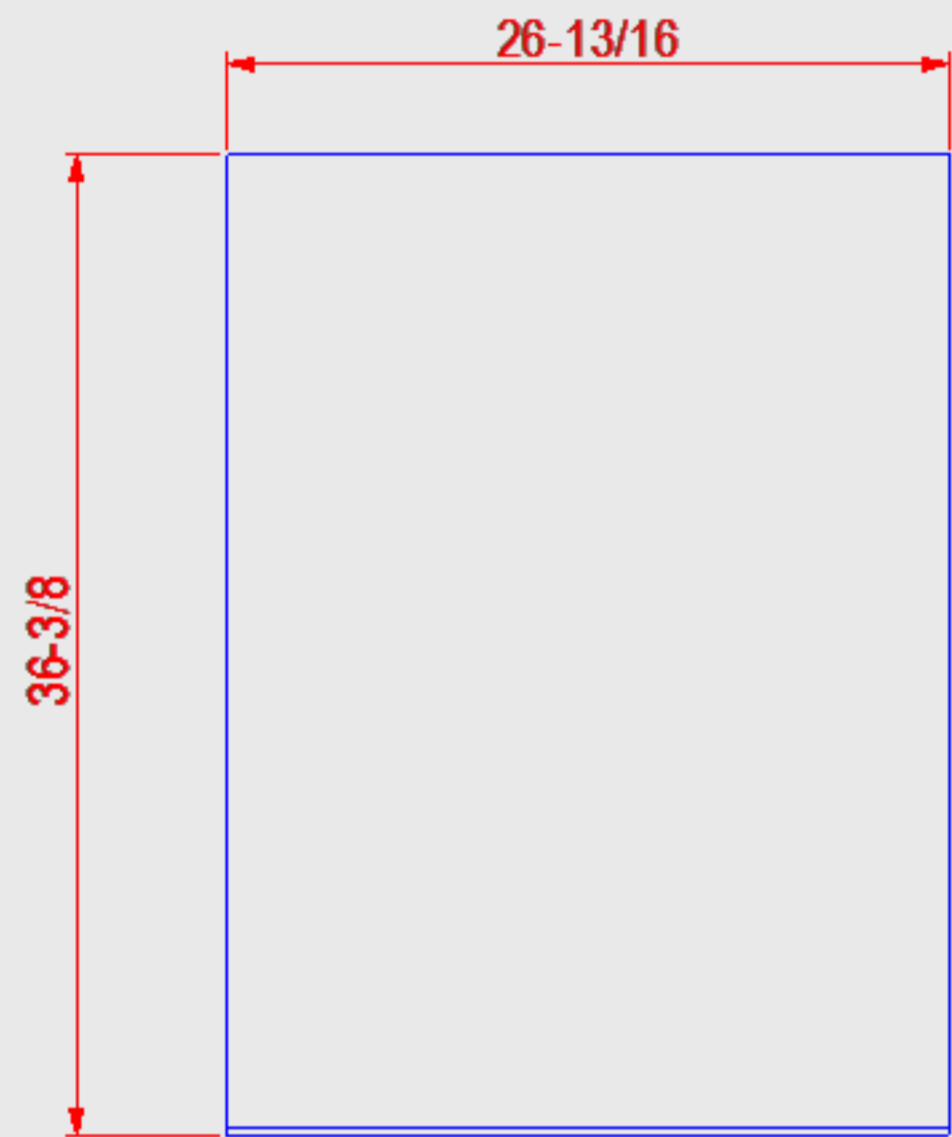
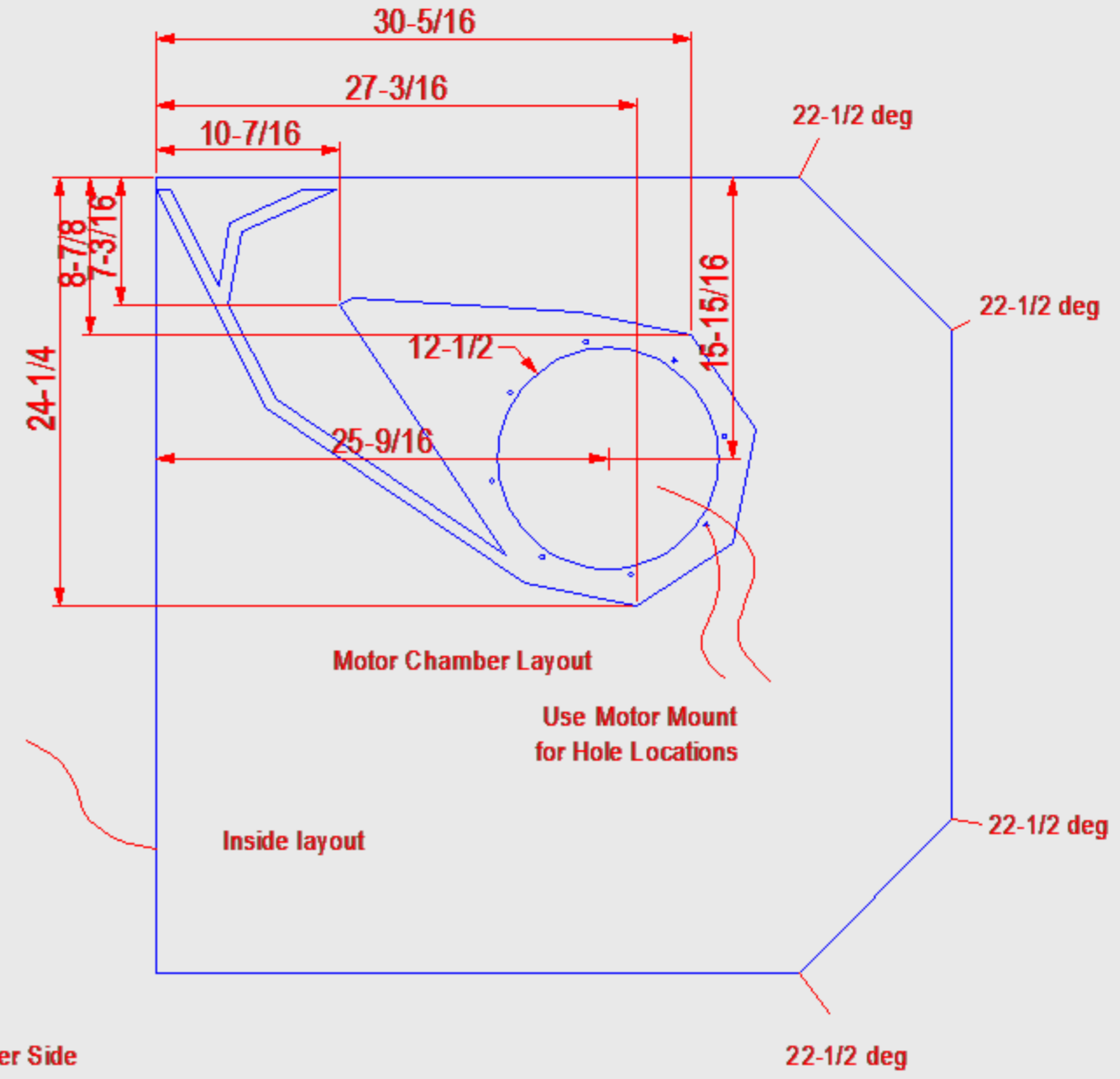
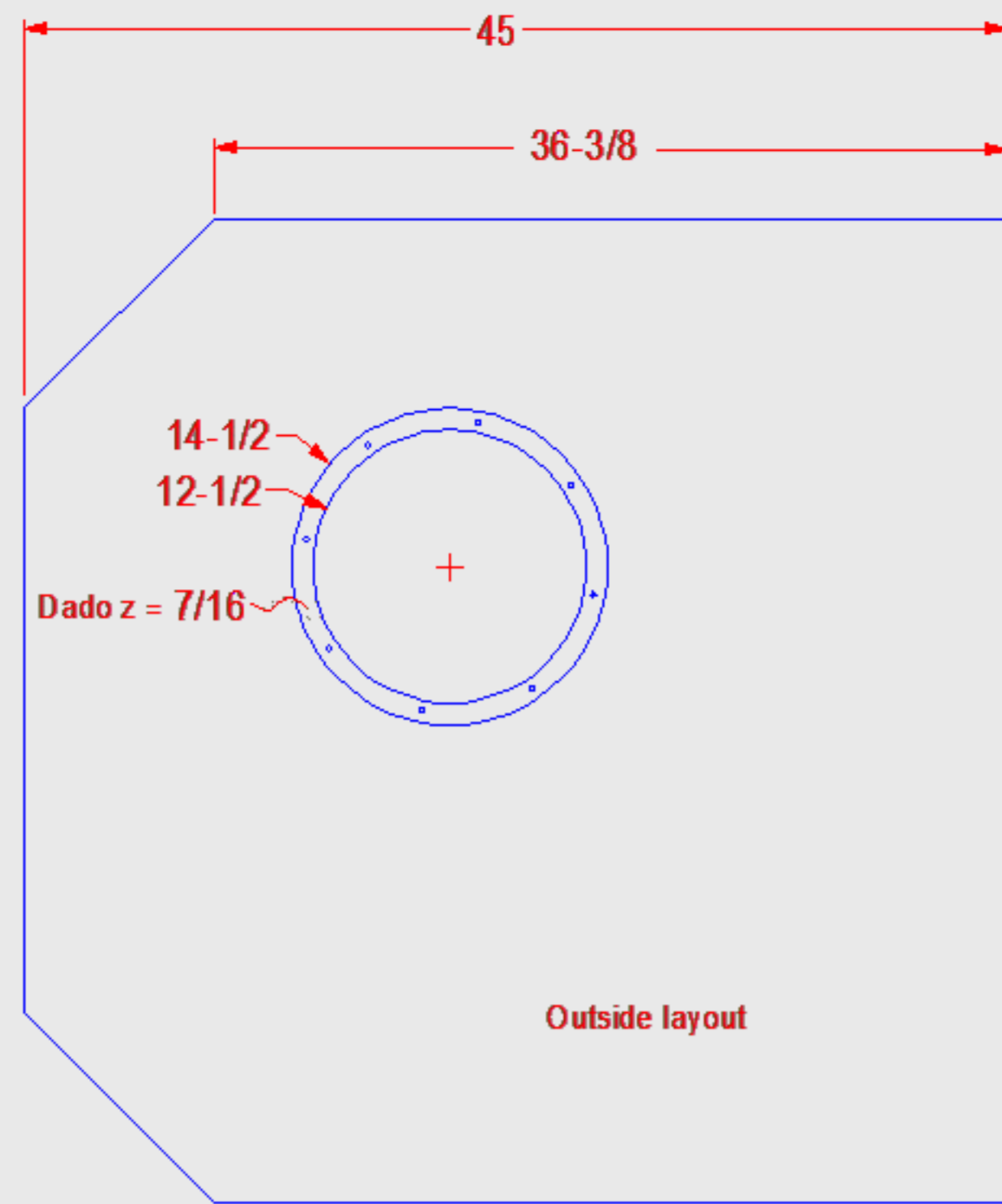

22-1/2 deg



22-1/2 deg



22-1/2 deg

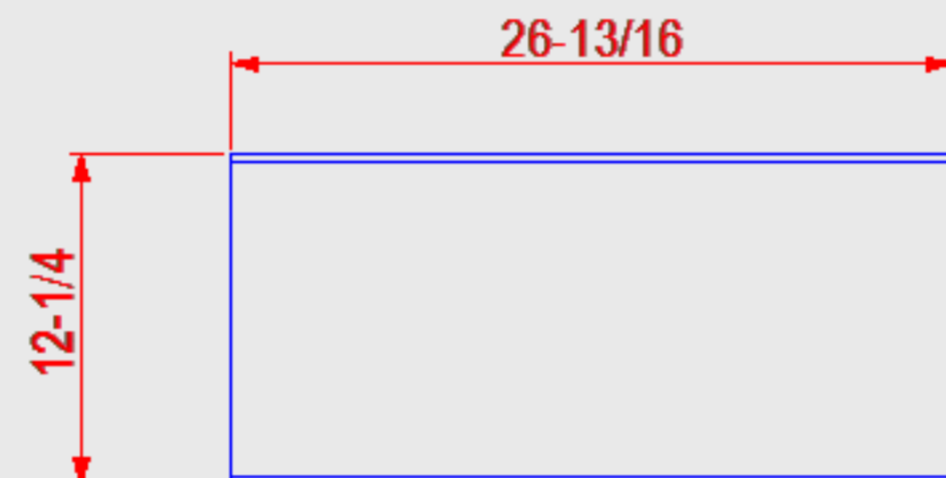

22-1/2 deg

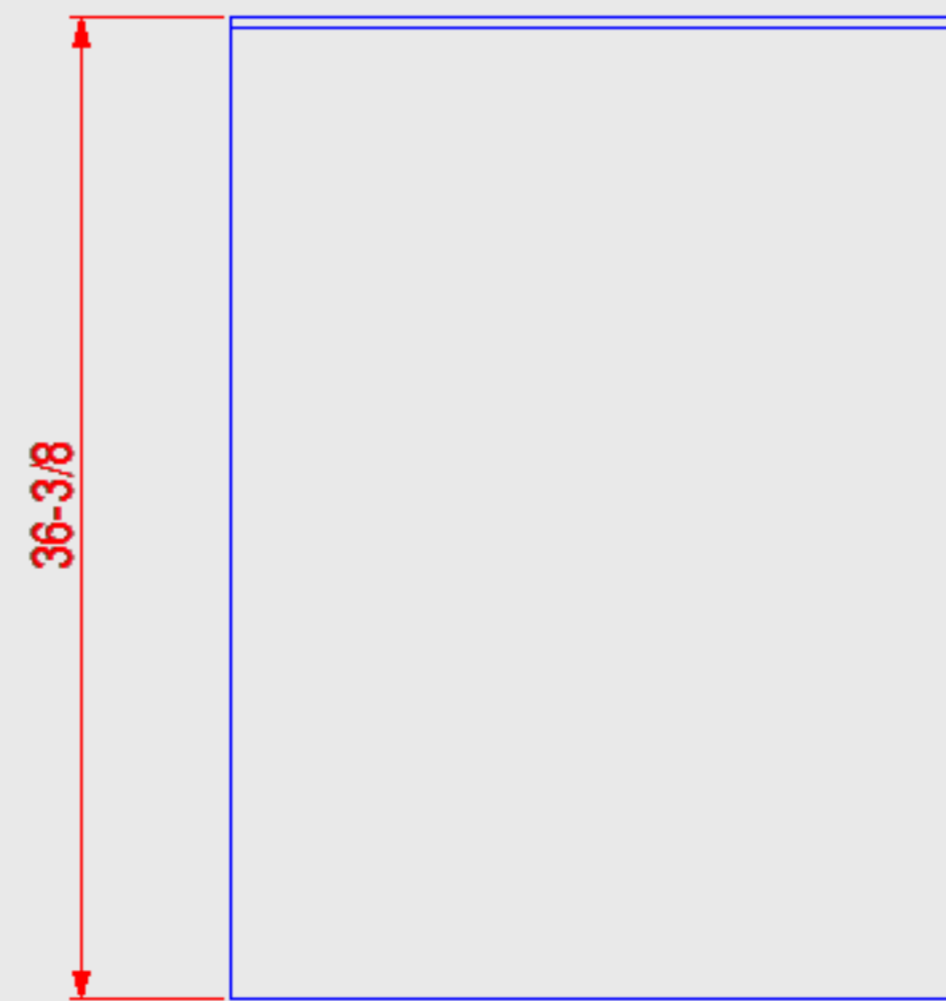

22-1/2 deg

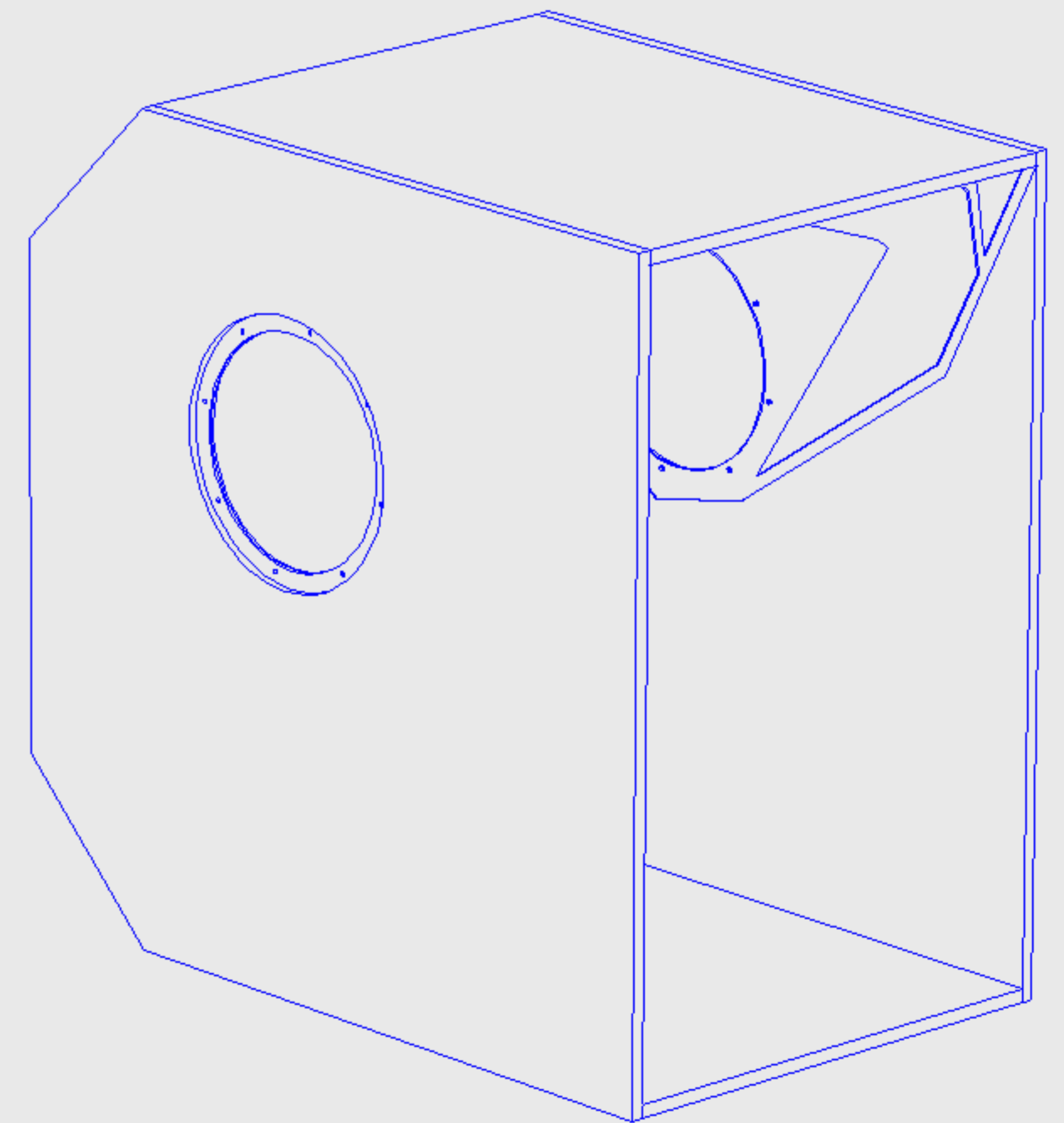

MOTOR CHAMBER SUPPORTS

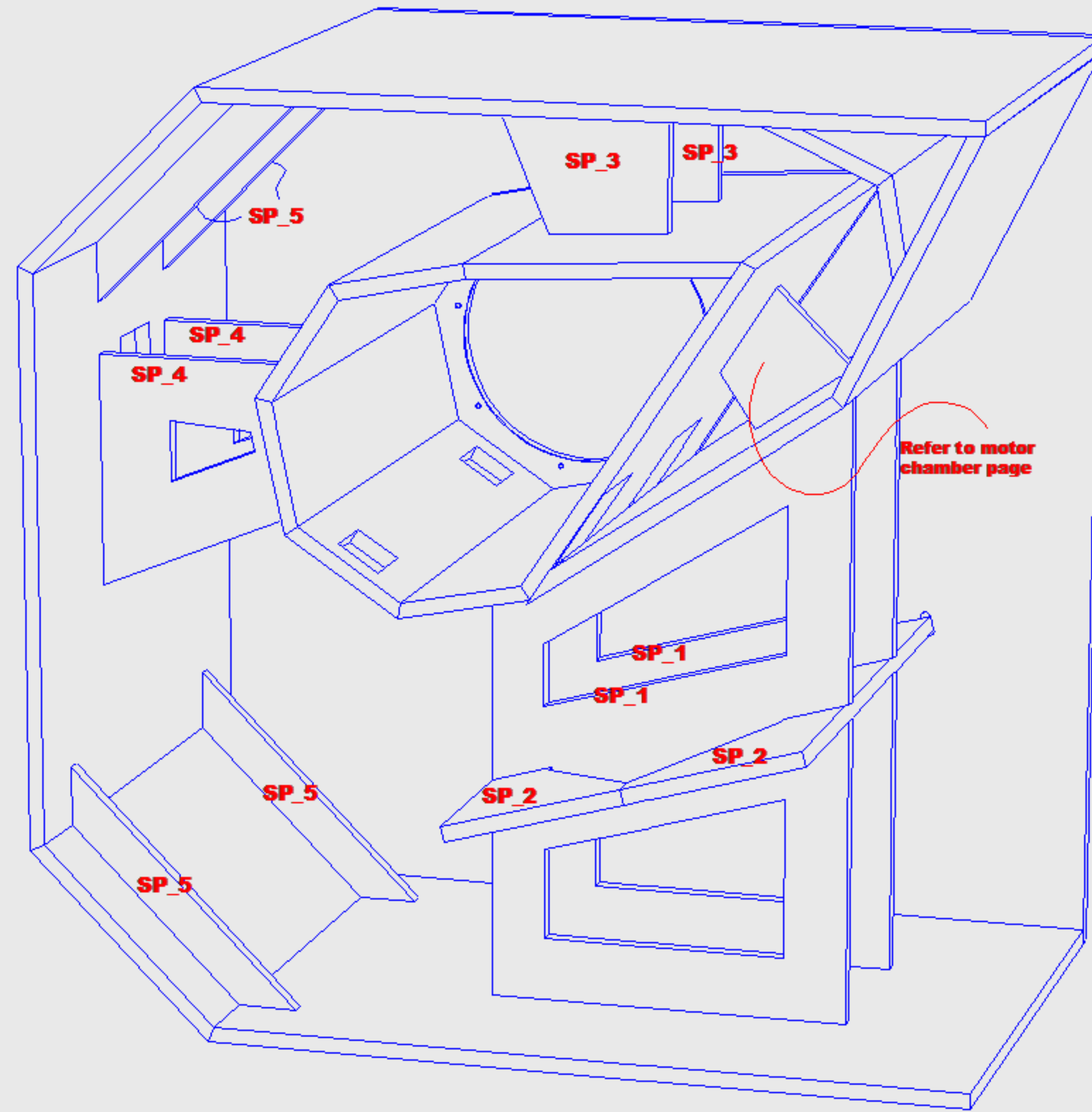
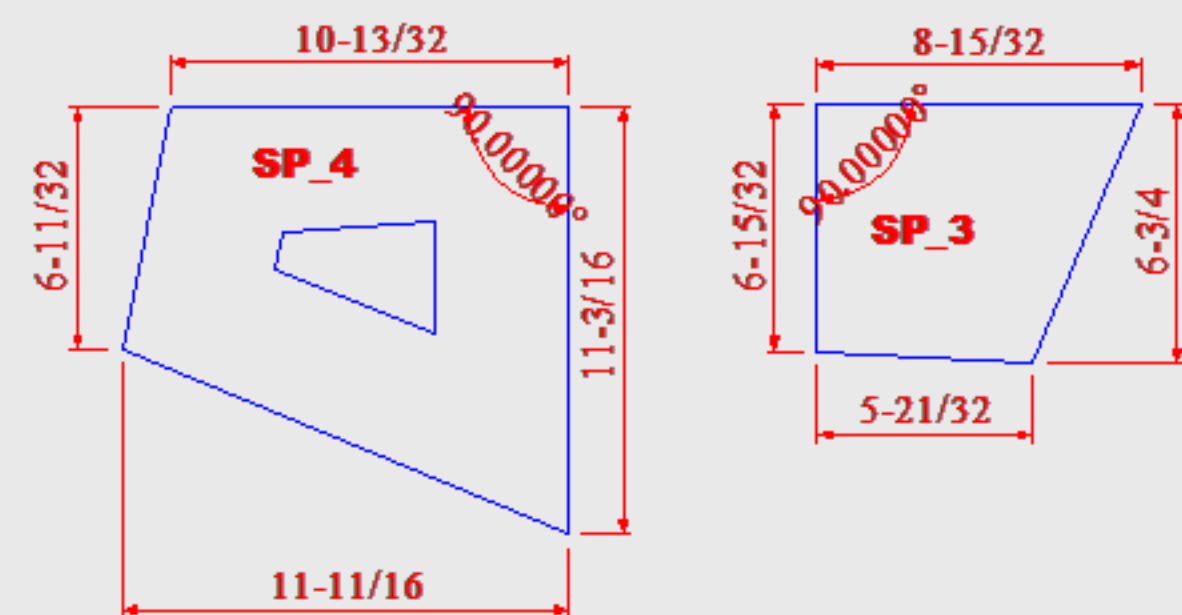
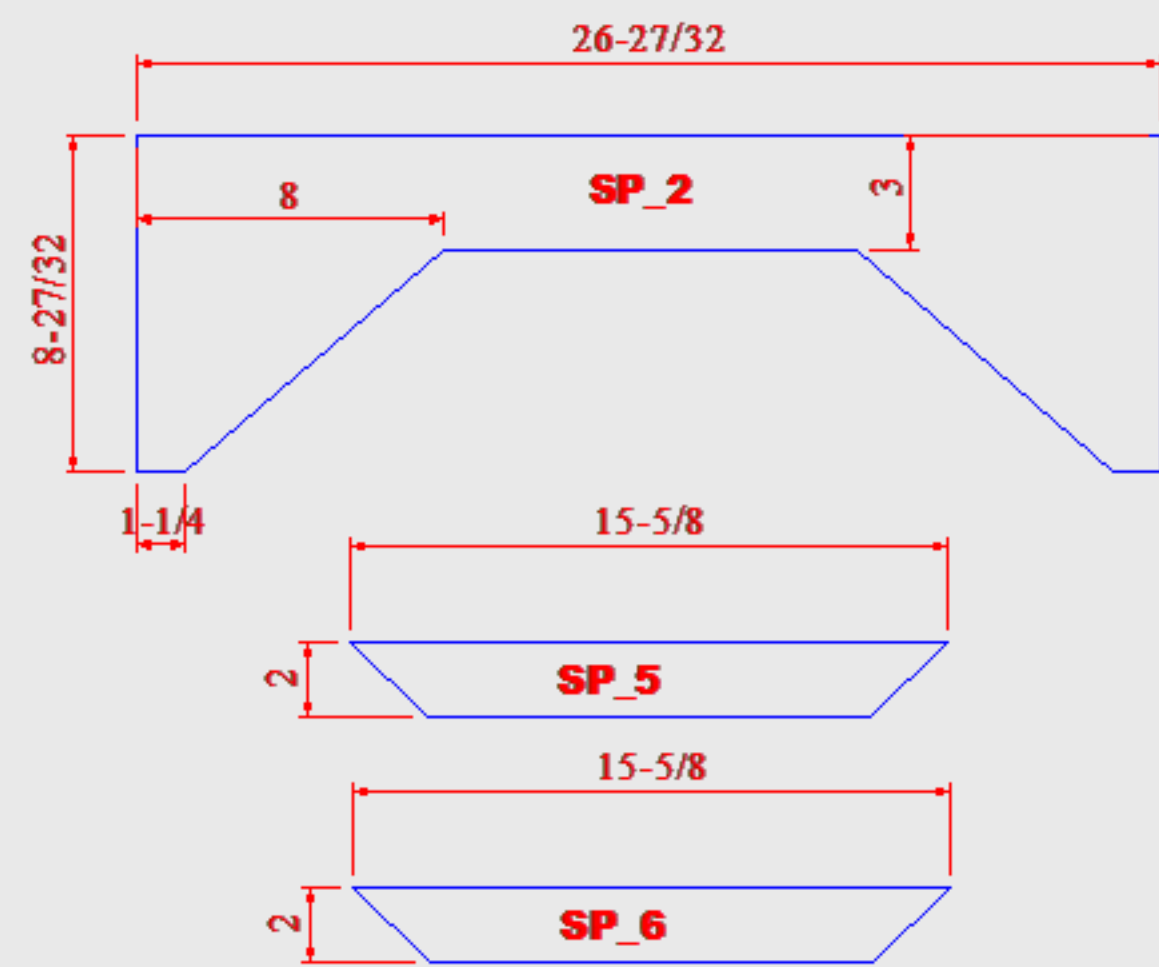
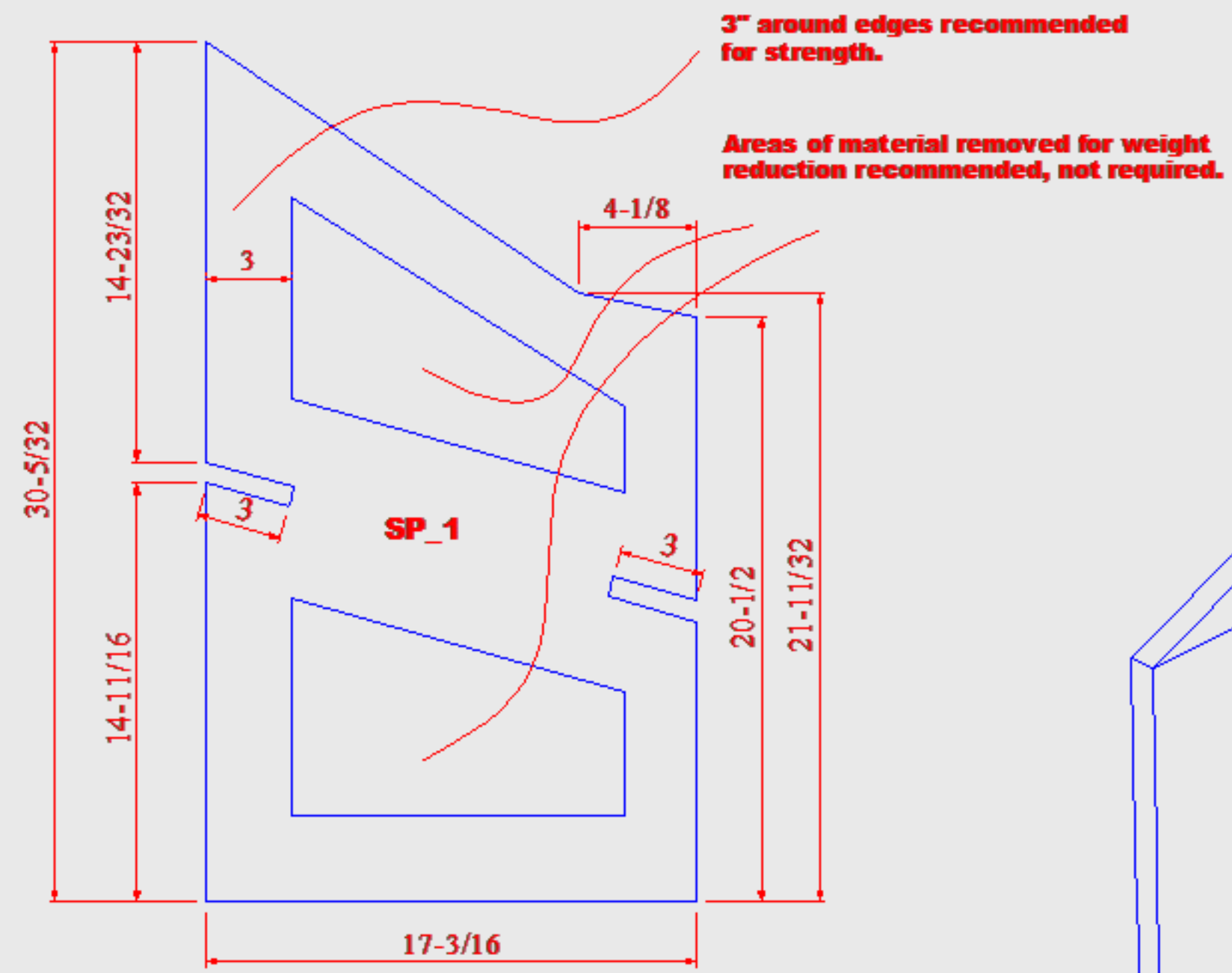

Spacing for Supports
Top View

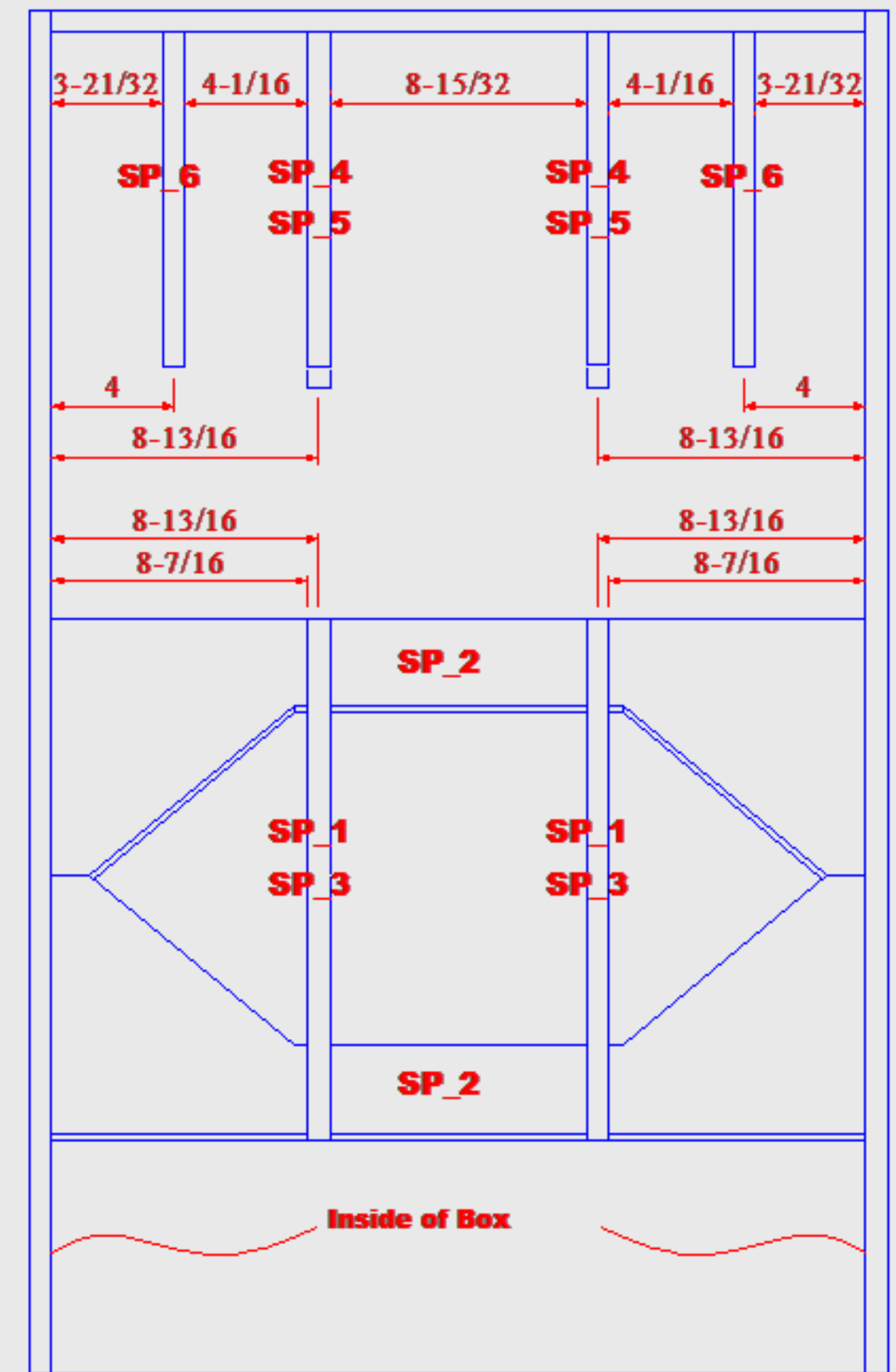

MOTOR CHAMBER

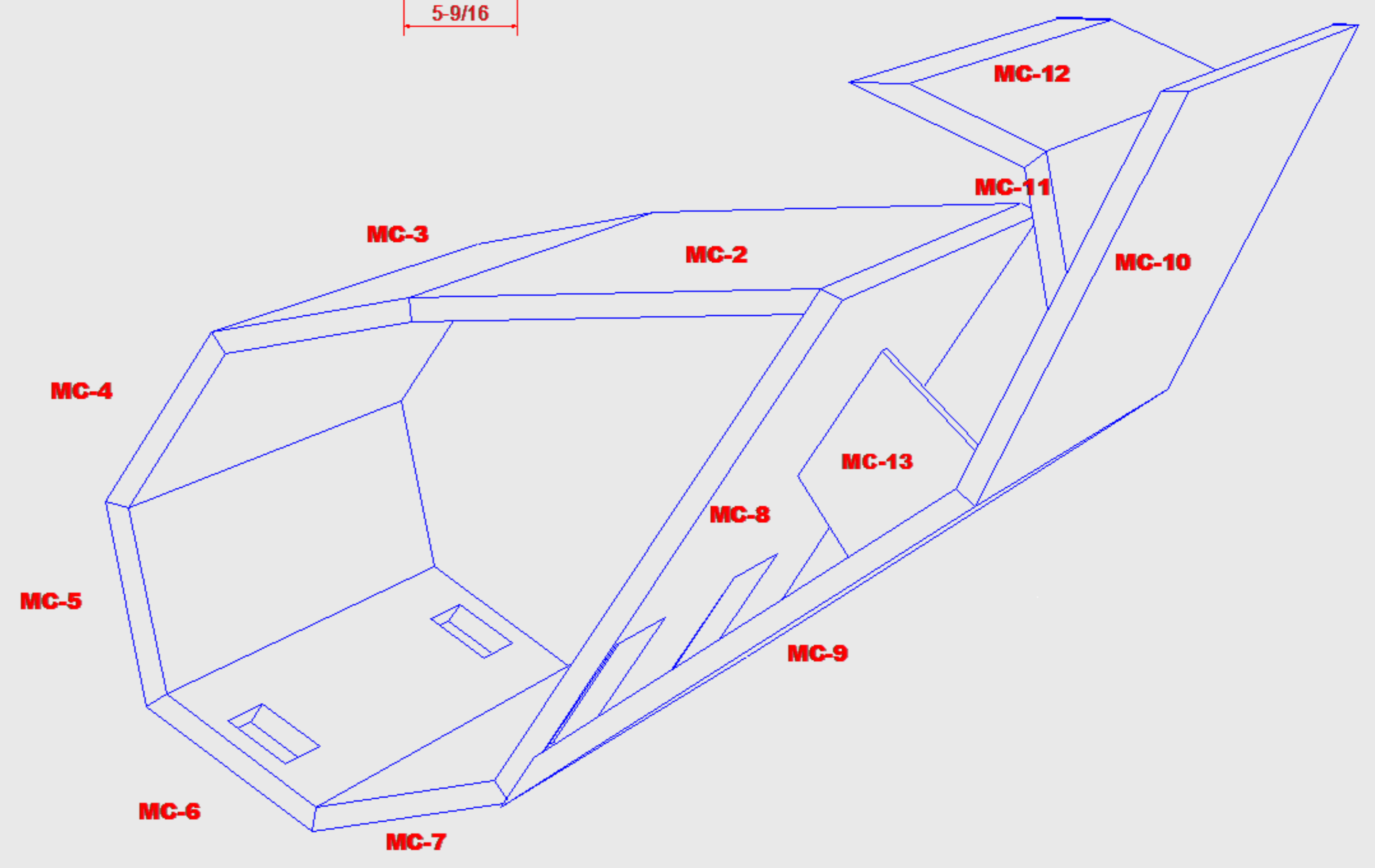
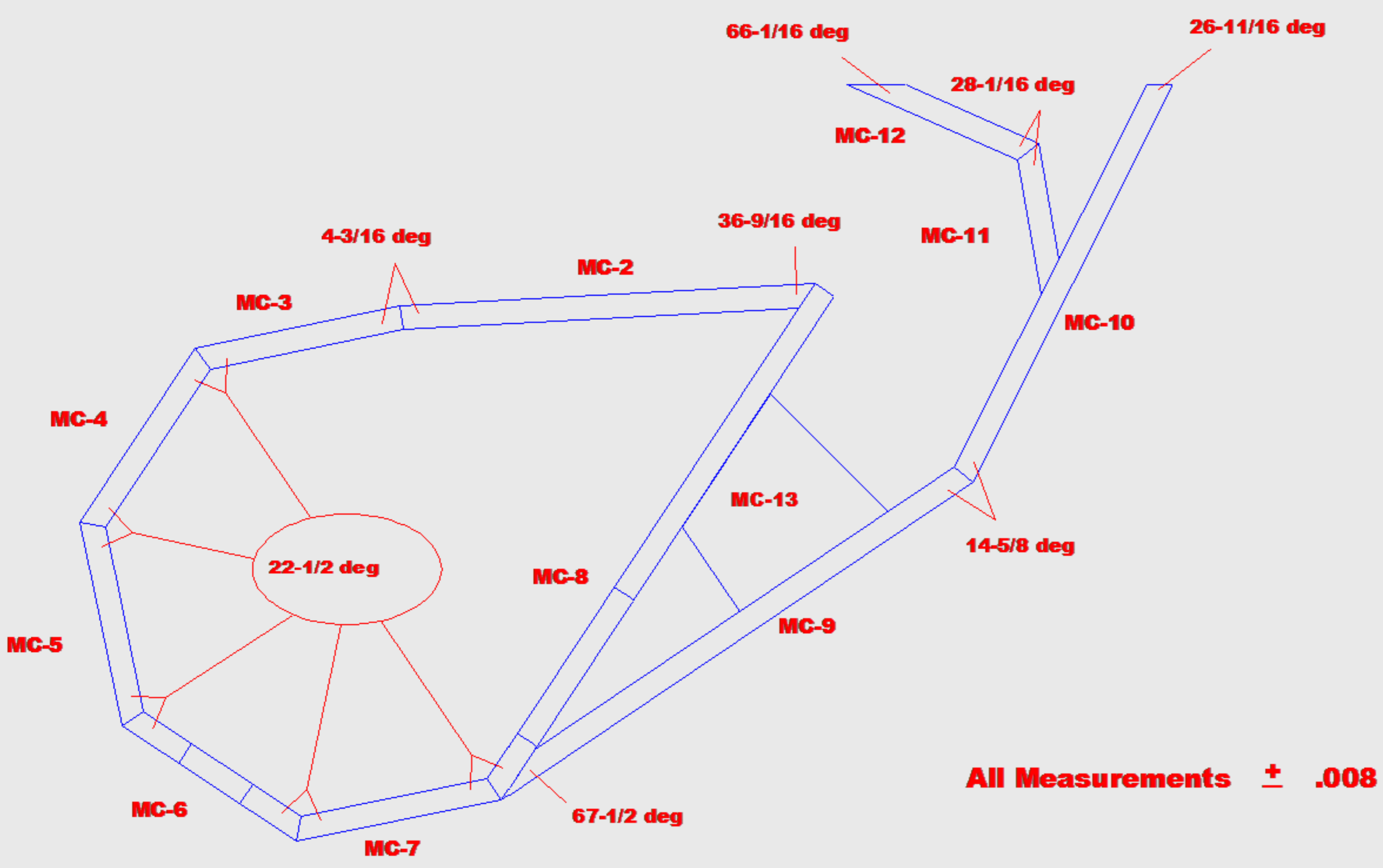
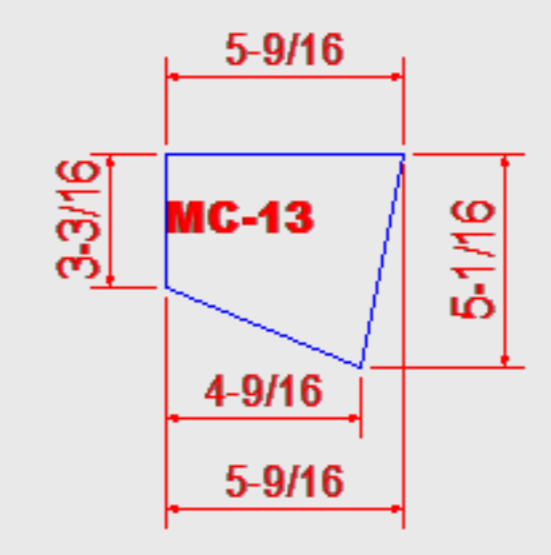
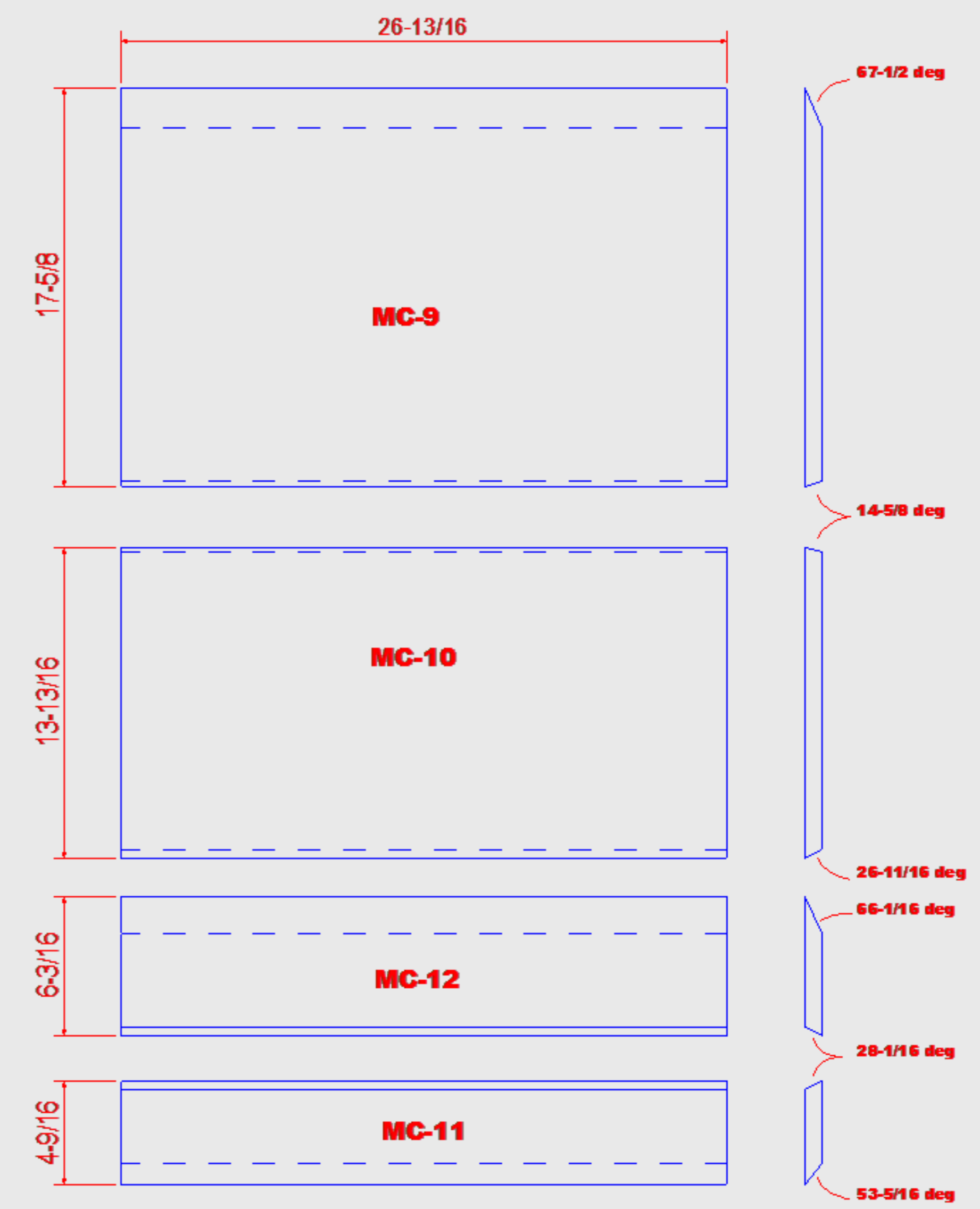
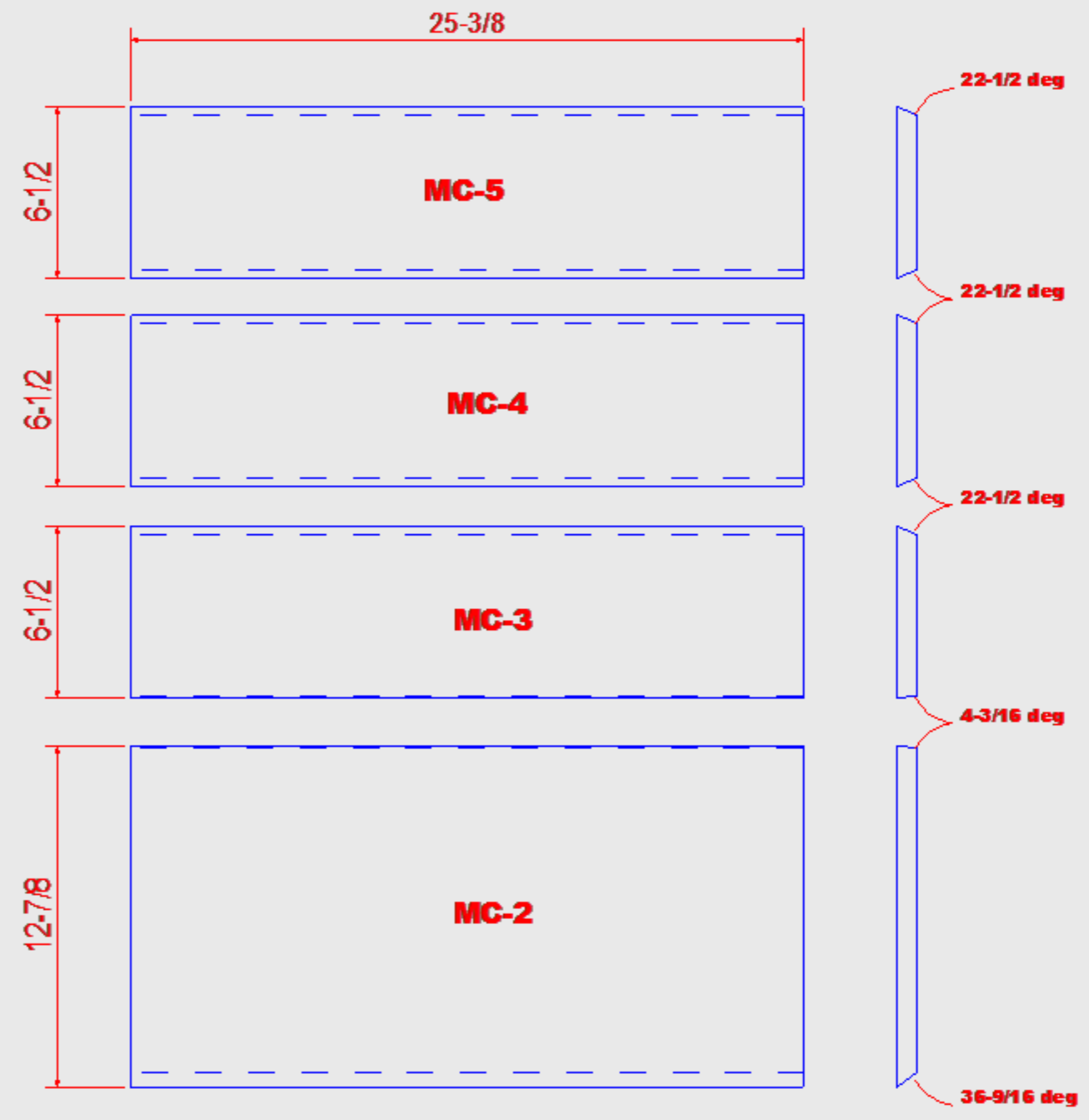
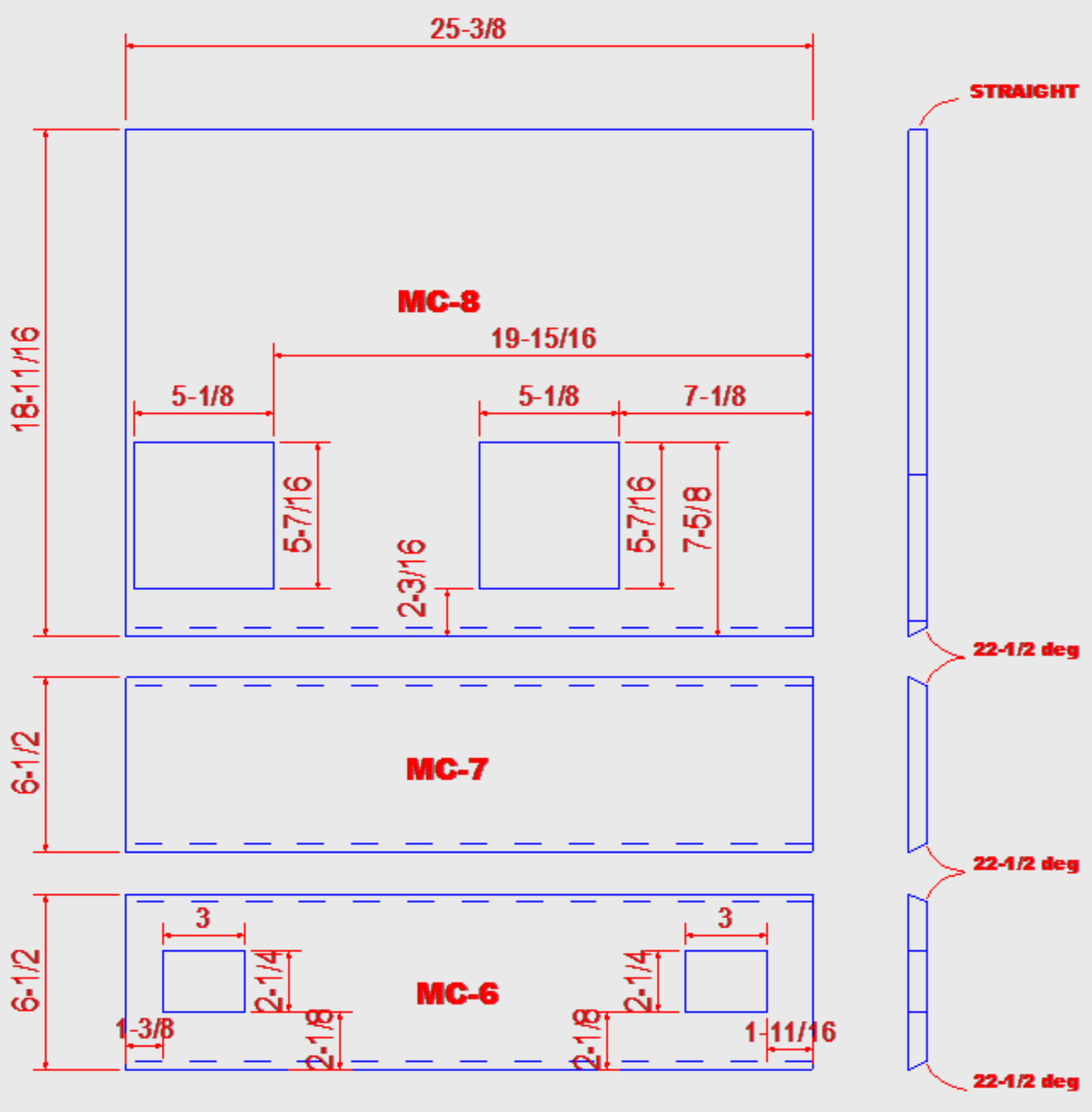

All Measurements \pm .008

Motor Chamber Fill

Note: Fill must be AIRTIGHT, forming a sealed front chamber for each driver. Rear chamber space is formed by the areas adjacent to the front chambers.

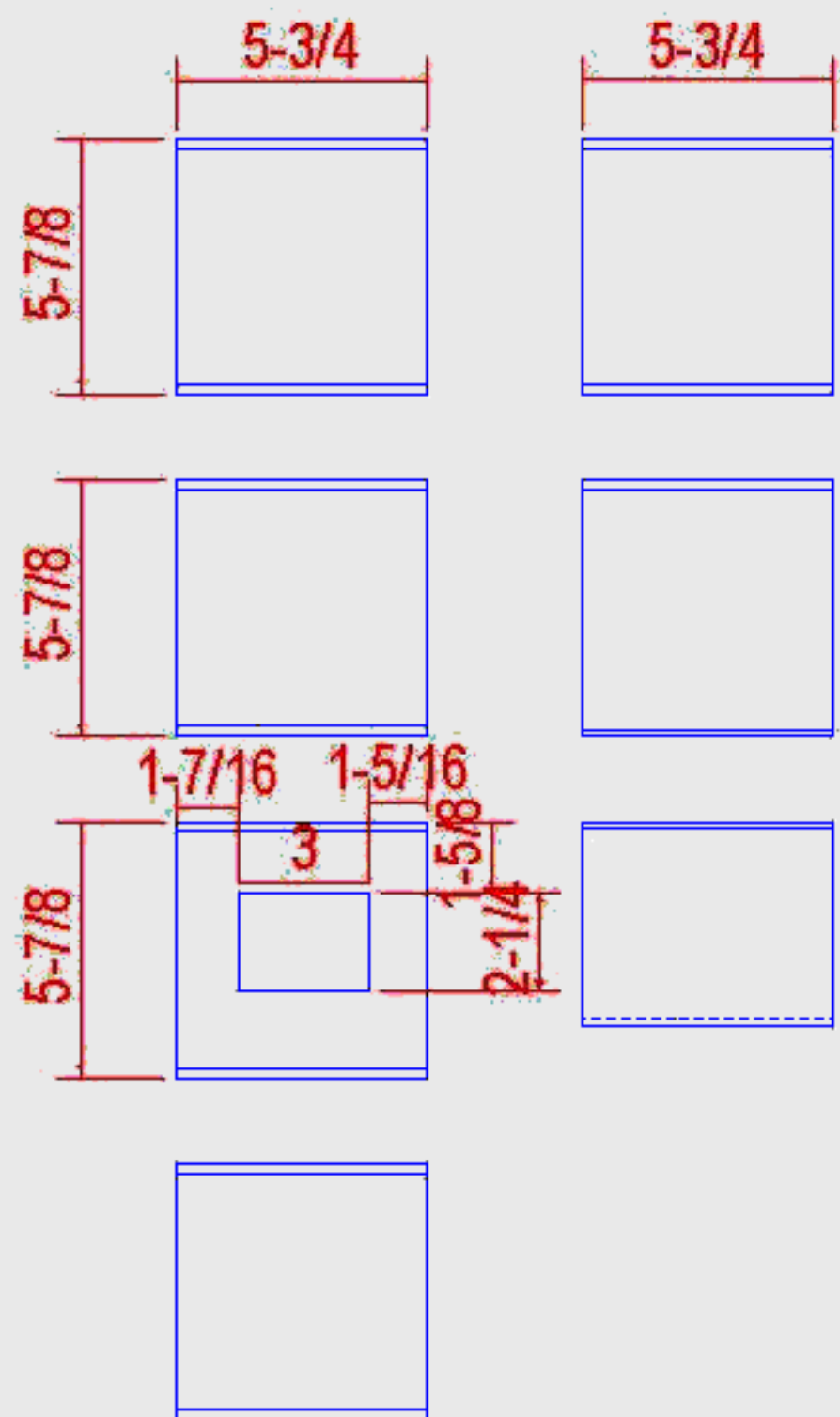

Left Chamber

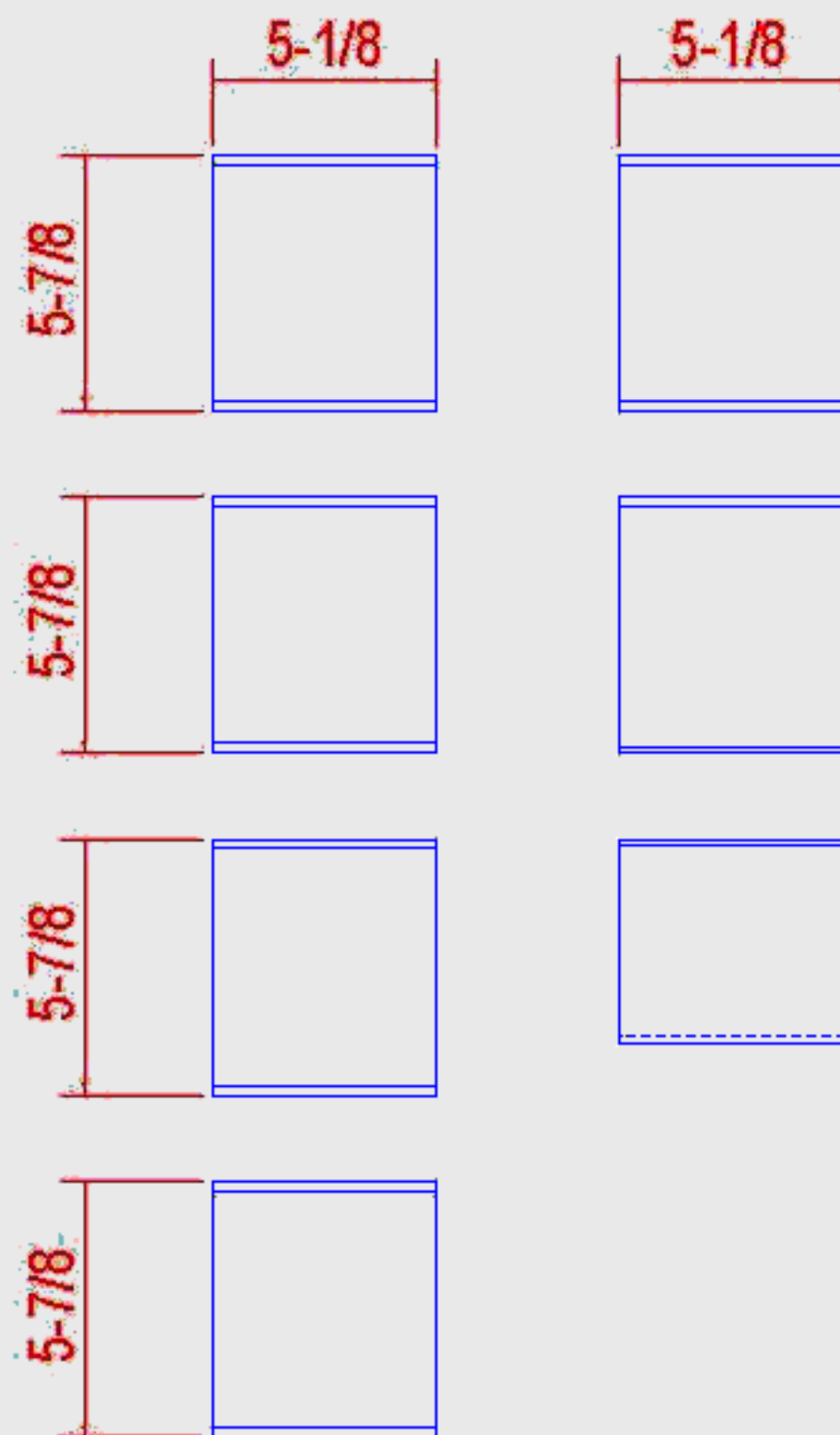

Right Chamber

All $22\text{-}1/2$ deg cuts, except where shown

Motor Mounts

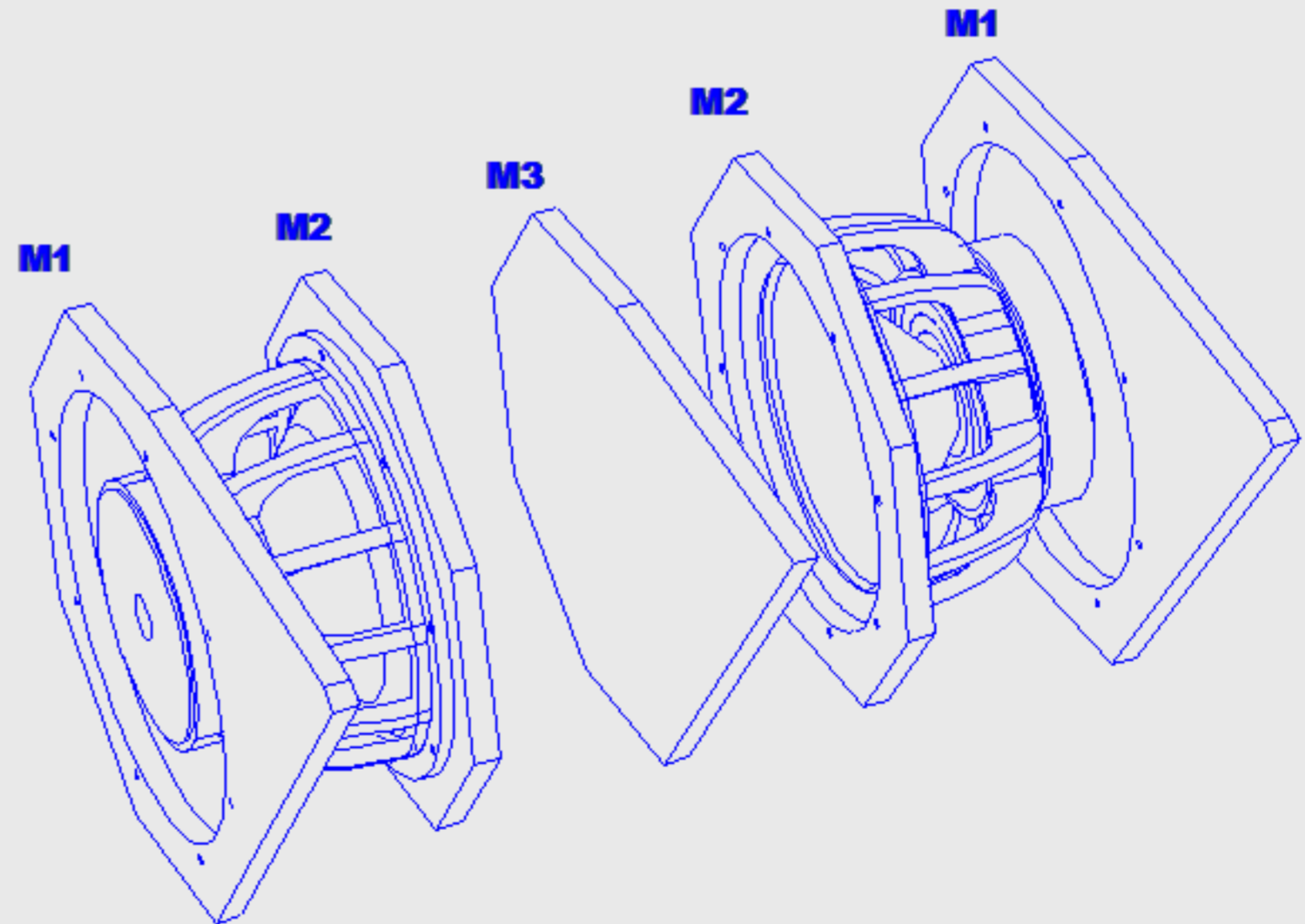
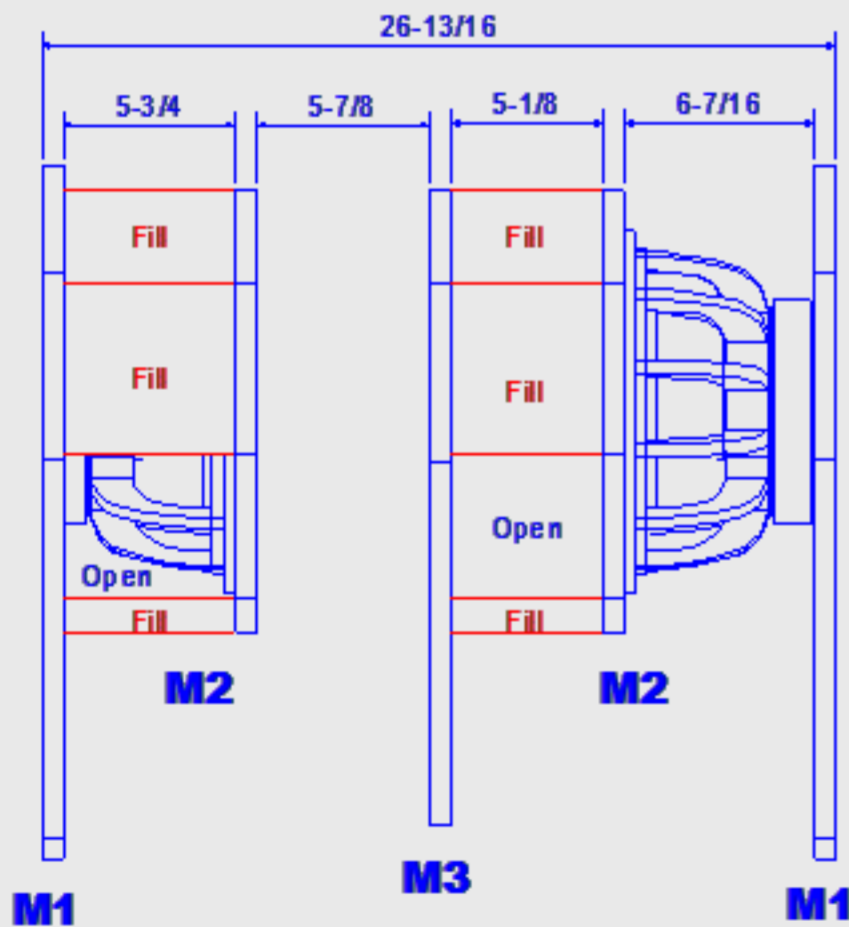
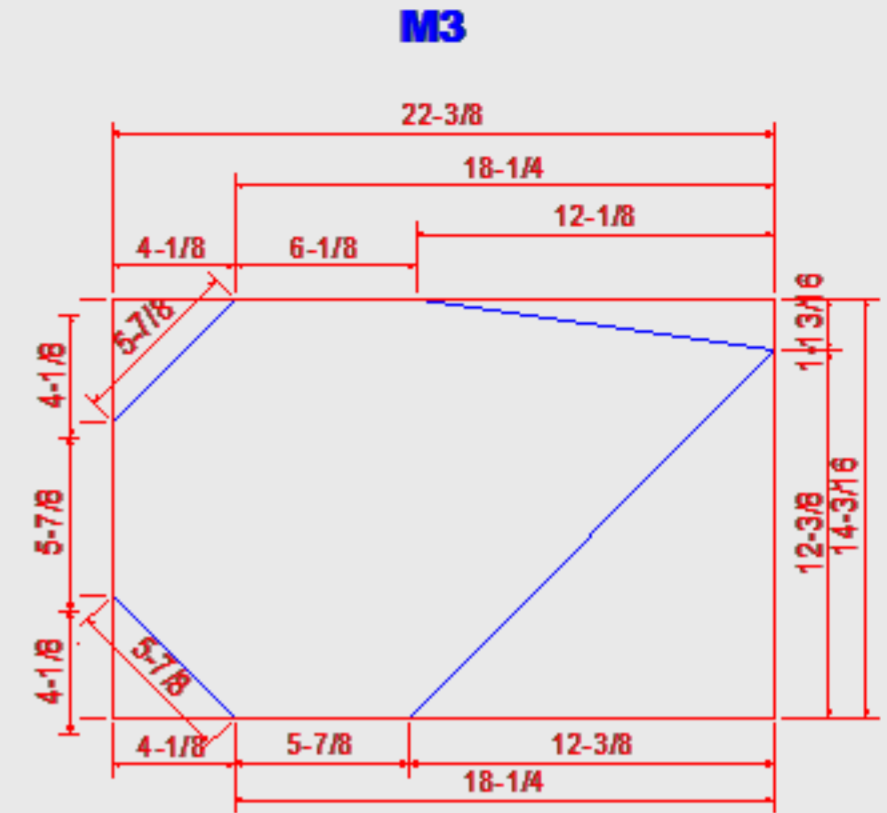
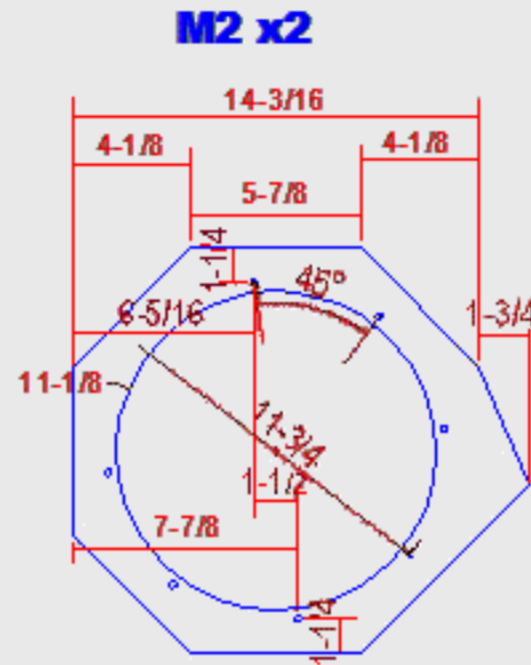
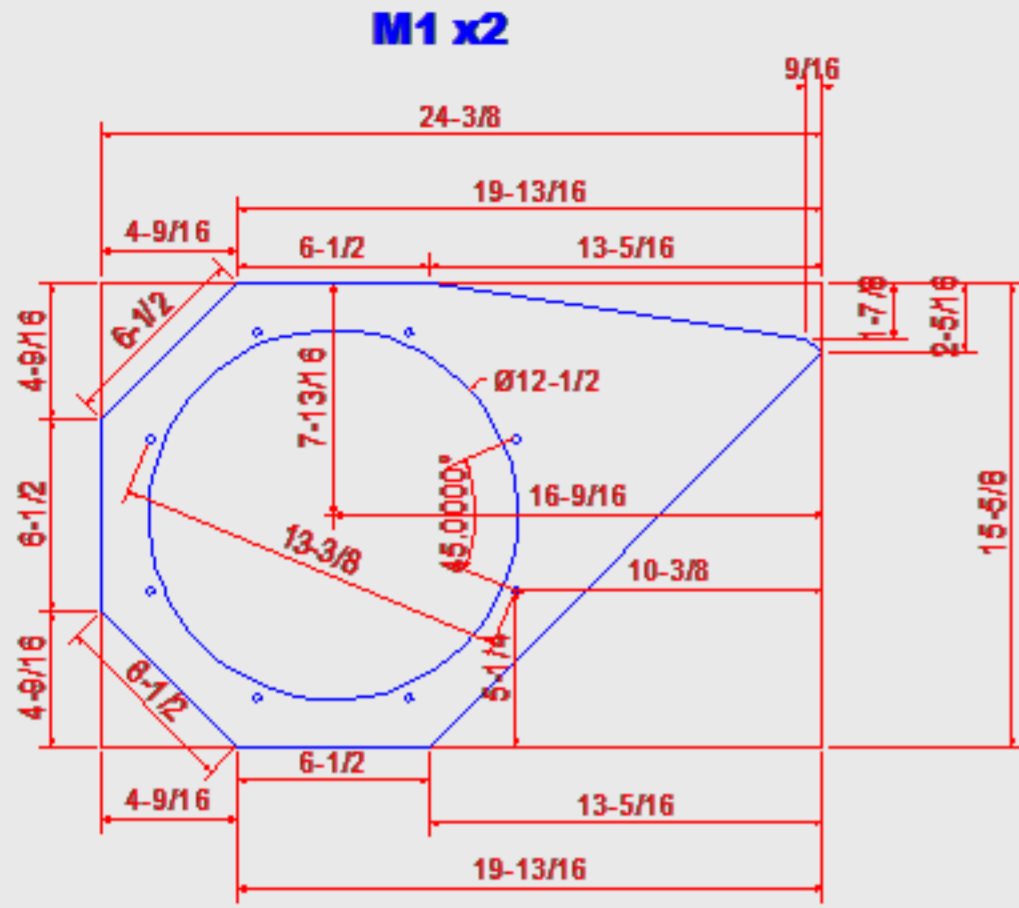

Note: Fill must be **AIRTIGHT**, forming a sealed front chamber for each driver. The opening must be sealed to throat panel MC-8. (See motor chamber detail)

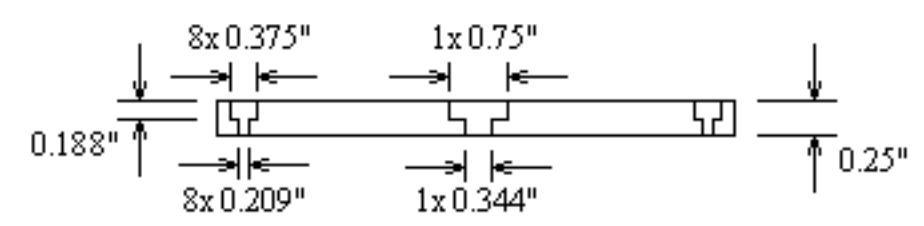
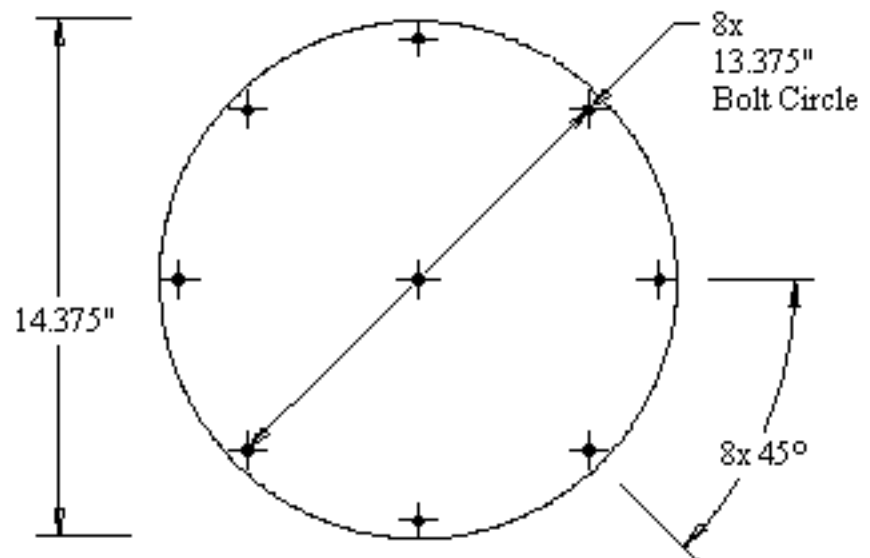

NOTE:
MATERIAL 5052 ALUMINUM .25 THICKNESS

UNLESS OTHERWISE SPECIFIED: DIMENSIONS ARE IN INCHES.
BREAK SHARP CORNERS .010-.030. SHEET METAL FABRICATION TOLERANCES PER
S-8410. CONCENTRICITY (T.I.R.) OF ANY TWO MACHINED DIAMETERS AROUND A COMMON
AXIS SHALL BE WITHIN 1/2 THE SUM OF THE TOTAL TOLERANCES ON THOSE DIAMETERS.

THE PROPERTY OF π Speakers AND MUST NOT BE REPRODUCED OR USED IN ANY MANNER DETRIMENTAL TO INTEREST OF SAID COMPANY.	<h1>π Speakers</h1>		TULSA, OKLAHOMA
	<h2>Access Panel</h2>		
UNLESS OTHERWISE SPECIFIED FRACTIONAL: $\frac{1}{2}$ DID ANGULAR: MACH $\pm 1/2^\circ$ X $\frac{1}{2}$ DSD XX $\frac{1}{2}$ DSD XXX $\frac{1}{2}$ DID SURFACE FINISH: 12S AA	DRAWN:	SCALE:	MATERIAL: NOTED
	CHKD:	DATE: 08/29/2005	DRAWING NO.:
	E.C.R. NO.:	APPD:	

REV	CHANGE DESCRIPTION	BY	DATE	CHKD

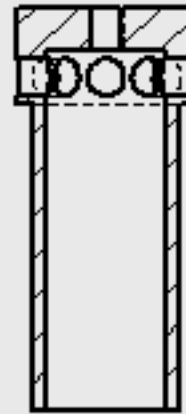
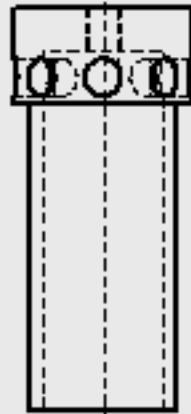
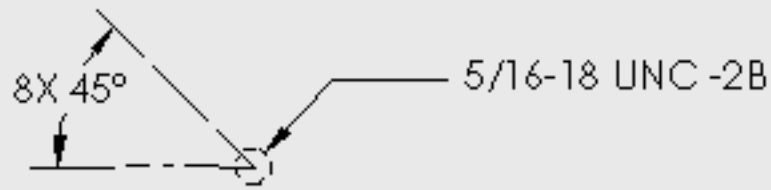

NOTE:

MATERIAL 6061 ALUMINUM ROD 1.5 NOM. DIA.



UNLESS OTHERWISE SPECIFIED: DIMENSIONS ARE IN INCHES.
BREAK SHARP CORNERS .010-.030. SHEET METAL FABRICATION TOLERANCES PER
S-8410. CONCENTRICITY (T.I.R.) OF ANY TWO MACHINED DIAMETERS AROUND A COMMON
AXIS SHALL BE WITHIN 1/2 THE SUM OF THE TOTAL TOLERANCES ON THOSE DIAMETERS.

THE PROPERTY OF π Speakers AND MUST NOT BE REPRODUCED OR USED IN ANY MANNER DETRIMENTAL TO INTEREST OF SAID COMPANY.	<h1>π Speakers</h1>		TULSA, OKLAHOMA
	<h2>Cooling Plug</h2>		
UNLESS OTHERWISE SPECIFIED FRACTIONAL: \pm .010 ANGULAR: MACH \pm 1/2° X \pm .005 XX \pm .003 XXX \pm .001 SURFACE FINISH: 125 AA	DRAWN: MDV	SCALE:	MATERIAL: NOTED
	CHECKED: MDV	DATE: 08/01/2005	DRAWING NO.
	E.C.R. NO.:	APPD:	

REV	CHANGE DESCRIPTION	BY	DATE	CHKD
-----	--------------------	----	------	------

Speakon

NL4

1+

1-

2-

2+

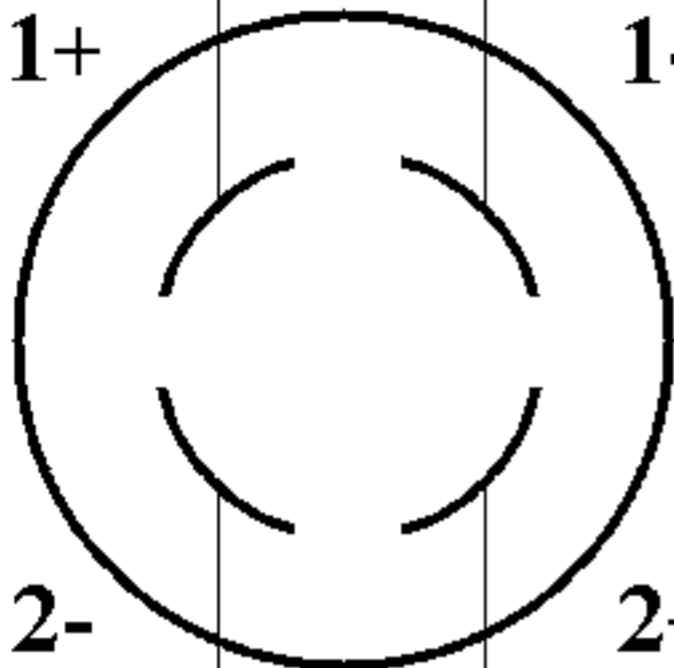

**Motor chamber
passthrough
connectors**

**Left woofer
(facing front)**

Reversed

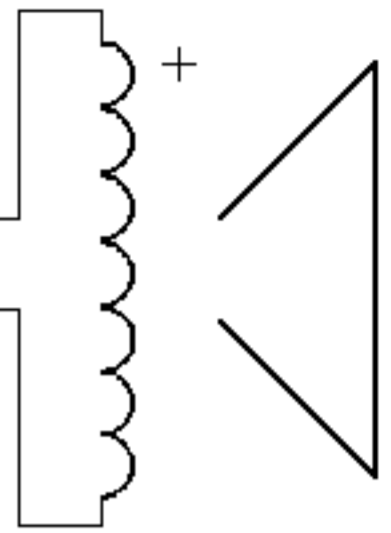

Speakon

NL4

1+

1-

2-

2+

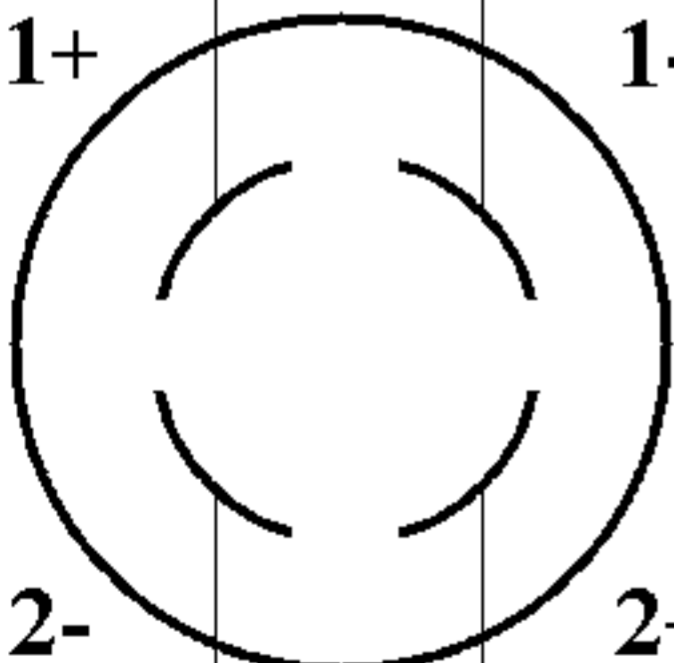

**Right woofer
(facing front)**

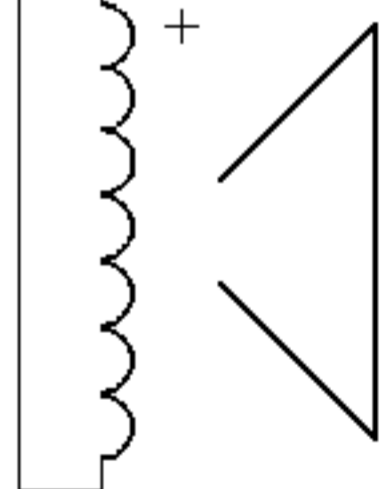

π Speakers

unmatched quality - state-of-the-art performance

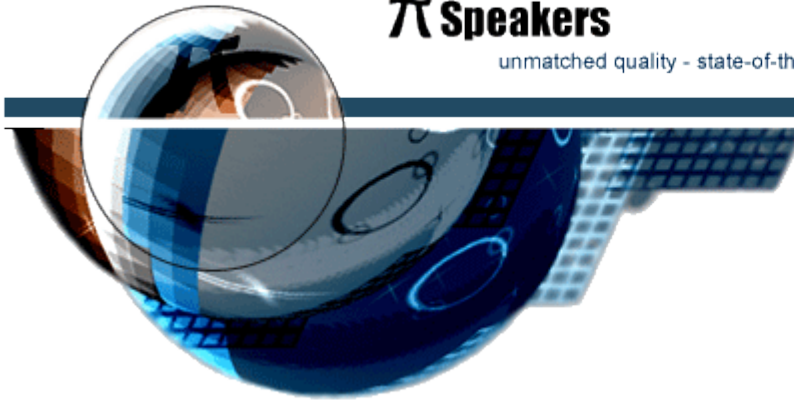

Speaker Motor Cooling System

Here are some photos of the cooling plug:



Cooling plug



Top View



Bottom View

The cooling plug is made of 6061 aluminum, which is a good conductor of heat. Its purpose is to conduct heat away from the motor and into the access panels, which double as heat sinks. This cools the motor a lot better than air cooling alone would do.

Ideally what you want is a uniform snug fit. Not so snug that the plug binds when inserting or removing it, but certainly not loose either. The best thermal interface is made when there is a lot of common surface area between the plug and pole piece and when there is pressure between the two. The other thing to balance this goal with is ease of assembly and service, which deters us from over-sizing the plug and pressing it in. The best fitment is to have one to two thousandths of an inch fit.

Our woofers are machined for precise fitment of the cooling plug in the pole piece. For this reason, we suggest you order your woofers and cooling plugs directly from us. We have an OEM woofer made specifically for this application.

LAB12 woofers can be used but they aren't machined so the pole piece vent ID varies by as much as 0.050". For do-it-yourself builders that prefer to machine their own parts, here are a few suggestions.

Cooling plugs are available in two sizes, 1.235" and 1.250". Measure your woofer and if it has pole piece ID smaller than 1.235", use the smaller plug and if not, use the larger plug. Machine the pole piece to fit, either 1.235" or 1.250" +0.002/ -0.000.

If the cooling plug nearly fits into the center pole, then you may be able to clean the paint from the ID with sandpaper and have a good fit. However, be aware that the back plate is pressed onto the center pole, slightly compressing the pole piece ID in this area. There is a good chance that this is the only place the cooling plug will make contact if the woofer isn't machined. This would not provide adequate contact surface area, so the thermal interface would not be good.

Drills can be used, but drilling is less precise, especially hand drills. A drill press can be used and you can expect precision on the order of +0.005/ -0.000. Holes drilled with hand drills are generally less precise. A 31mm drill bit is 1.220", 1-15/64" is 1.234", 31.5mm is 1.240" and 1-1/4 is 1.250".

Be careful when machining the pole piece so that iron filings do not enter the voice coil gap. The magnet is actually very effective at capturing the debris and preventing it from falling through the pole piece onto the cone and possibly back around into the gap. Just use caution and work slowly and carefully.

After machining is finished, remove any paint that remains on the ID surface with sandpaper and clean the area. If the machined surface is going to sit a while before assembly, be sure and leave a light coat of oil or heat sink compound on the exposed steel, to prevent rust.

When installing the device, be sure to use heat conductive grease. It is very important that the interface between the pole piece on the motor and the cooling plug is good. You want a lot of surface area contact, so the entire length of the cooling plug should be inserted and it should be covered with conductive grease. You also want the interface between the cooling plug and the heat exchanger to be good, so use conductive grease there too, and snug the panel down well. Both surfaces should be straight and smooth to maximize contact surface area.



Heat conductive grease on pole piece, in vent hole



Cooling plug inserted, ready to attach to the heat exchanger



Heat conductive grease applied to cooling plug prior to attaching heat exchanger plate



Fastening the plate to the cooling plug



Heat exchanger assembled and ready



Heat exchanger assembly inserted in woofer

After the cooling plugs are inserted, they do not need any additional maintenance. They will work as heat sinks for the life of the loudspeaker. The access panels do not need a lot of airflow to work properly, because they have a lot of surface area.

Keep out of direct sunlight. This is probably the most important advice. Several 12π basshorns can be stacked together with no ill-effects, but one placed in direct sunlight on a hot summer day will quickly heat the access panel to a point where it is ineffective as a heat sink. Provide shade to 12π basshorns that will be used in direct sunlight. This can be accomplished using a denim flap hung loosely over the access panels.
